



1350V,30A,Field Stop , IGBT

TO-247-3L (*Prefix :W)

V _{CES}	1350V
I _c (T _c 100°C)	30A
V _{CE(sat)} (typ)	1.7V

DESCRIPTION

- Positive temperature coefficient
- Low saturation voltage
- Has low conduction loss and switching loss
- Easy paralleling
- Rohs Compliant

APPLICATIONS

- Motor drives
- Inverters
- Uninterruptible Power Supplies
- Converters

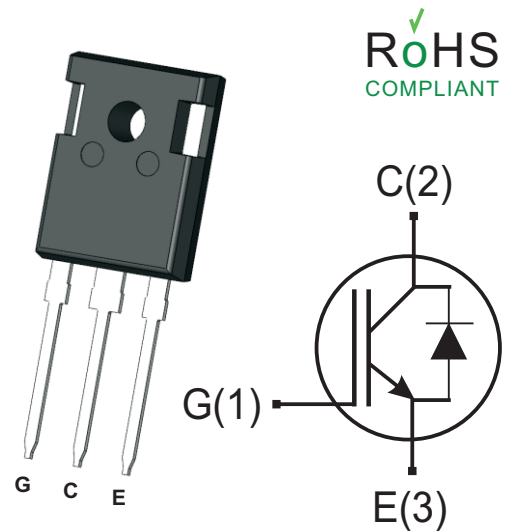

ROHS
COMPLIANT

SYMBOL

ABSOLUTE MAXIMUM RATINGS (TA=25°C, unless otherwise specified)

PARAMETER	Symbols	RATINGS	Units
Collector-Emitter Breakdown Voltage	V _{CE}	1350	V
Continuous Gate-Emitter Voltage	V _{GE}	±20	V
DC Collector Current, limited by T _{jmax}	I _c	T _c =25°C	60
		T _c =100°C	30
Pulsed Collector Current	I _{CM}	120	A
Diode Forward Current, limited by T _{jmax}	I _F	30	A
T _c =100°C			
Power Dissipation (T _c = 25°C)	P _D	250	W
Operating junction temperature	T _j	-55 ~ +150	°C
storage temperature	T _{stg}	-55 ~ +150	°C

Thermal Resistance

PARAMETER	Symbols	RATINGS	Units
Thermal resistance IGBT junction – case.	R _{thJC}	0.5	°C/W
Thermal resistance Diode junction – case.	R _{thJC}	0.43	°C/W
Thermal resistance, junction – ambient	R _{thJA}	40	°C/W



Electrical Characteristics of the IGBT (Tj= 25°C unless otherwise specified)

PARAMETER	Symbols	TEST CONDITIONS	Min	Typ	Max	Units
Static						
Collector-emitter breakdown voltage	$V_{(BR)CES}$	$V_{GE}=0V, I_{CE}=0.25mA$	1350			V
Zero gate voltage collector current	I_{CES}	$V_{CE}=1350V, V_{GE}=0V$			10	μA
Gate-emitter leakage current	I_{GES}	$V_{GE}=\pm 20V, V_{CE}=0V$			± 100	nA
Collector-emitter saturation voltage	$V_{CE(sat)}$	$V_{GE}=15V, I_C=30A$		1.7	2.3	V
Gate-emitter threshold voltage	$V_{GE(TH)}$	$V_{GE}=V_{CE}, I_C=1mA$	3.5	5.8	7.5	V
Dynamic						
Input Capacitance	C_{ies}	$V_{CE}=25V,$		6840		μF
Output Capacitance	C_{oes}	$V_{GE}=0V,$		203		pF
Reverse Transfer Capacitance	C_{res}	$f=1.0MHz$		56		pF
Gate resistance	R_G	$V_{DS}=0V, F_{REQ}=1.00MHz$		1.0		Ω

Electrical Characteristics of the Diode (Tj= 25°C unless otherwise specified)

PARAMETER	Symbols	TEST CONDITIONS	Min	Typ	Max	Units
Static						
Diode Forward Voltage	V_F	$V_{GE}=0V, I_F=30A$		1.15	1.3	V
Dynamic						
Diode reverse recovery time	TRR	$I_F=0.5A, I_R=1.0A$ $I_{rr}=0.25A$			1000	ns

Switching Characteristic, Inductive Load

PARAMETER	Symbols	TEST CONDITIONS	Min	Typ	Max	Units
Dynamic						
Turn-on Delay Time	$t_{d(on)}$	$V_{CC}= 600V, I_C=30A,$ $V_{GE}= -15V\sim 15V,$ $R_g=12\Omega$		35		ns
Rise Time	t_r			36		ns
Turn-on Energy	E_{on}			2.2		mJ
Turn-off Delay Time	$t_{d(off)}$			190		ns
Fall Time	t_f			90		ns
Turn-off Energy	E_{off}			0.8		mJ



Typical Characteristics

Fig.1 Typical output characteristic

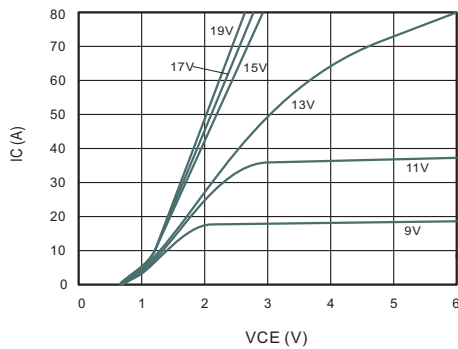

Fig.2 Capacitance Characteristics

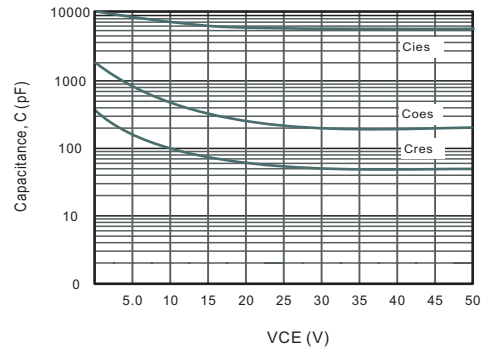

Fig.3 Power Dissipation

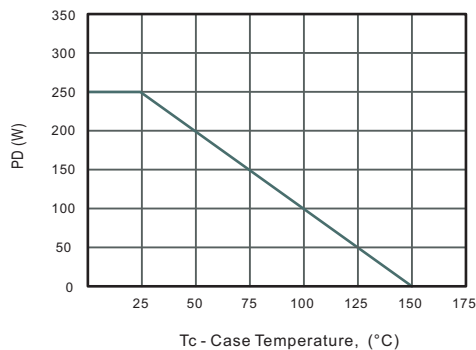

Fig.4 Collector Current Derating

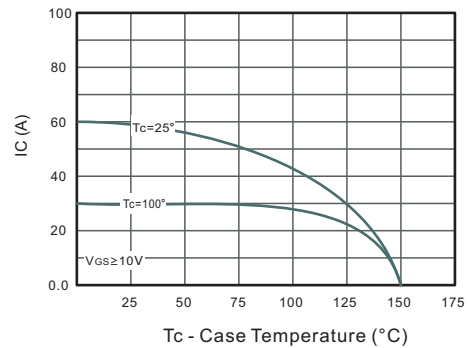

Fig.5 Max. Transient Thermal Impedance-IGBT

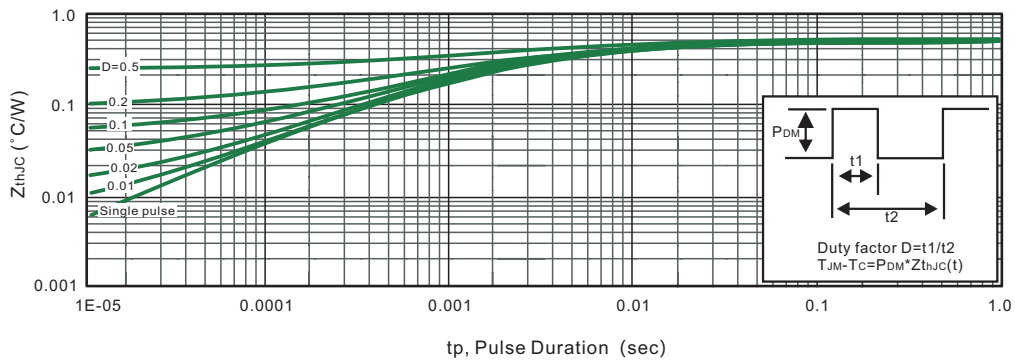
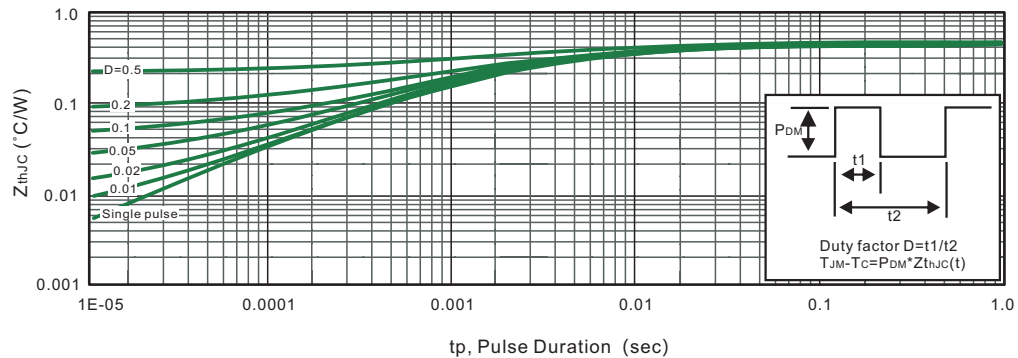

Fig.6 Max. Transient Thermal Impedance-Diode





Package Outline
Through Hole Package ; 3 leads

TO-247-3L

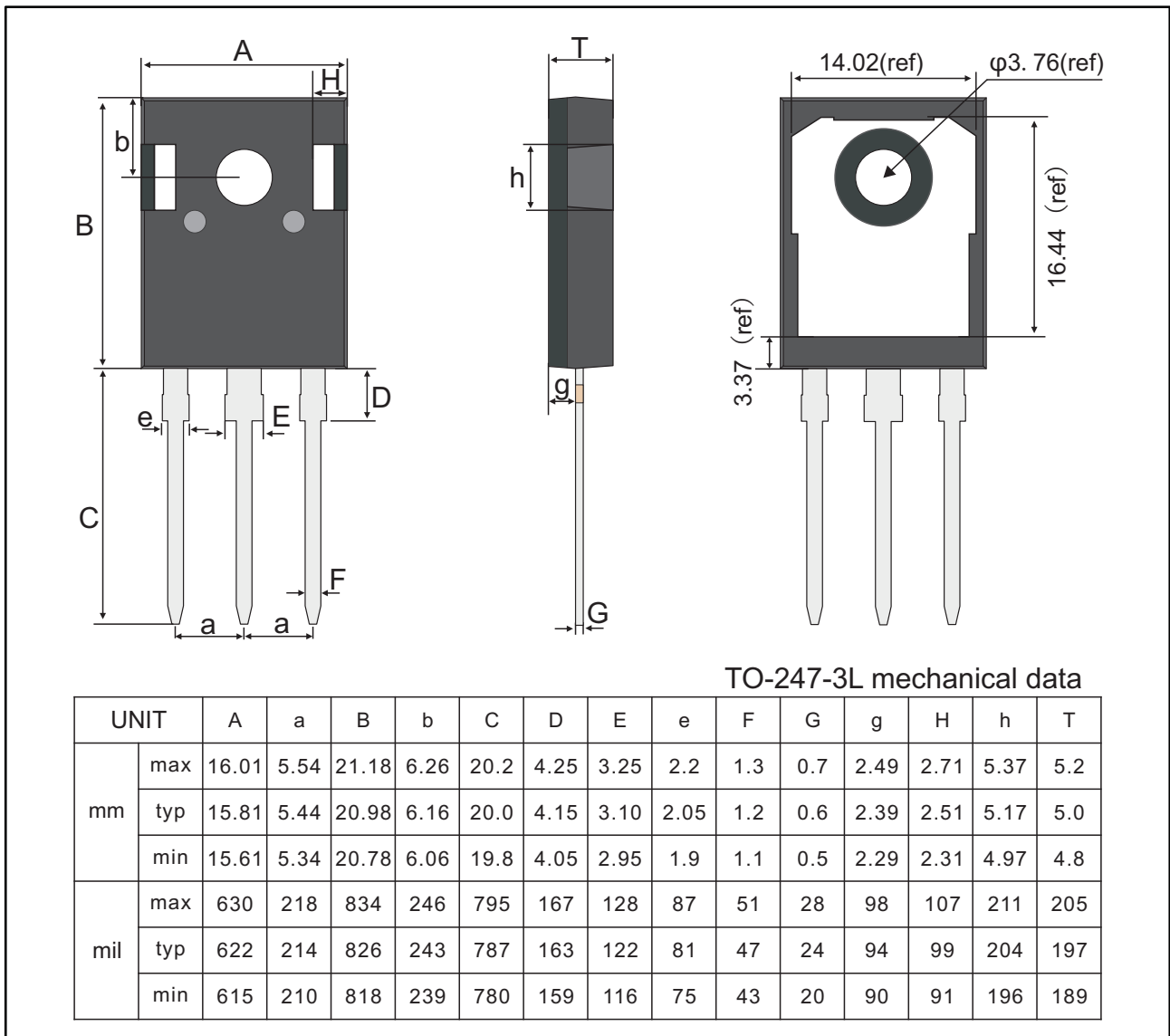

Marking

Type number	Marking code
GW30ND135ST	GW30ND135ST



Important Notice and Disclaimer

Jingdao Microelectronics reserves the right to make changes to this document and its products and specifications at any without notice.

Customers should obtain and confirm the latest product information and specifications before final, purchase or use.

Jingdao Microelectronics makes no warranty, representation or guarantee regarding the suitability of its products for any particular purpose, not does Jingdao Microelectronics assume any liability for application assistance or customer product design.

Jingdao Microelectronics does not warrant or accept any liability with products which are purchased or used for any unintended or unauthorized application.

No license is granted by implication or otherwise under any intellectual property rights of Jingdao Microelectronics.

Jingdao Microelectronics products are not authorized for use as critical components in life support devices or systems without express written approval of Jingdao Microelectronics.